

Part numbers:

- DEFA-PHM12/0500-EXT
- DEFA-PHM12-0800-EXT
- DEFA-PHM12-1200-EXT
- DEFA-PHM12-1600-EXT

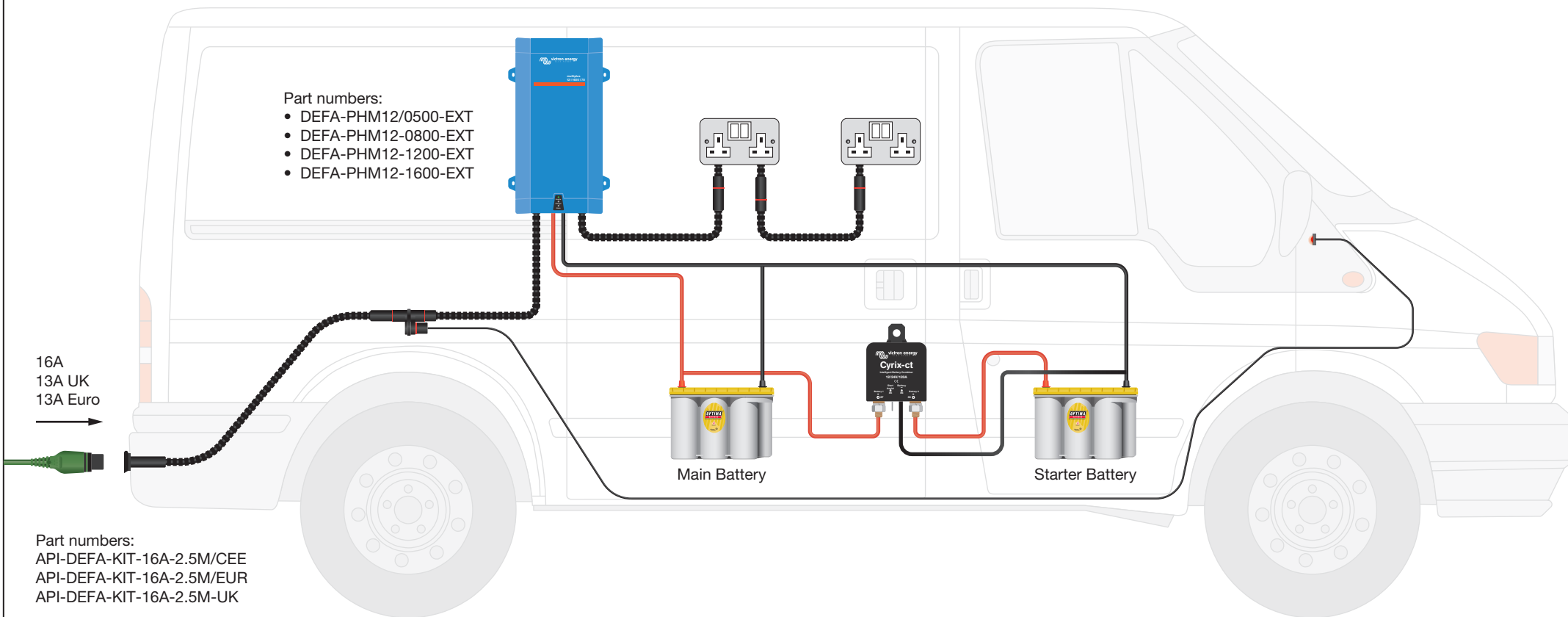

- Part numbers:
 API-DEFA-KIT-16A-2.5M/CEE
 API-DEFA-KIT-16A-2.5M/EUR
 API-DEFA-KIT-16A-2.5M-UK

Customer notes:

This is a single line drawing and not an installation drawing, please follow manufacturer installation instructions and manuals at all times.