



victron energy
BLUE POWER

Skylla TG Charger 24/48V

Skylla Charger 24/48V

Perfect chargers for any type of battery

Charge voltage can be precisely adjusted to suit any sealed or unsealed battery system. In particular, sealed maintenance free batteries must be charged correctly in order to ensure a long service life. Overvoltage will result in excessive gassing and venting of a sealed battery. The battery will dry out and fail.

Controlled charging

Every TG charger has a microprocessor, which accurately controls the charging in three steps. The charging process takes place in accordance with the IUoUo characteristic and charges more rapidly than other processes.

Use of TG chargers as a power supply

As a result of the perfectly stabilized output voltage, a TG charger can be used as a power supply if batteries or large buffer capacitors are not available.

Two outputs to charge 2 battery banks

The TG chargers feature 2 isolated outputs. The second output, limited to approximately 4 A and with a slightly lower output voltage, is intended to top up a starter battery.

To increase battery life: temperature compensation

Every Skylla TG charger comes with a battery temperature sensor. When connected, charge voltage will automatically decrease with increasing battery temperature. This feature is especially recommended for sealed batteries which otherwise might be overcharged and dry out due to venting.

Battery voltage sense

In order to compensate for voltage loss due to cable resistance, TG chargers are provided with a voltage sense facility so that the battery always receives the correct charge voltage.

Learn more about batteries and battery charging

To learn more about batteries and charging batteries, please refer to our book 'Energy Unlimited' (available free of charge from Victron Energy and downloadable from www.victronenergy.com).

Charge curve

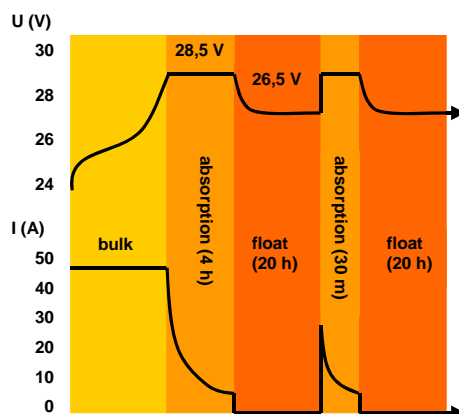

Application example

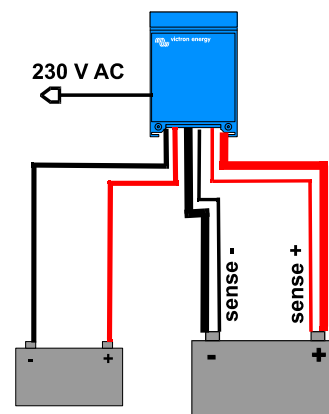



Skylla TG Charger 24/48V

Specifications

Skylla	24/30 TG 24/50 TG	24/50 TG 3 phase	24/80 TG	24/100 TG	24/100.TG 3 phase	48/25 TG	48/50 TG
Input voltage (V AC)	230	3 x 400	230	230	3 x 400	230	230
Input voltage range (V AC)	185-264	320-450	185-264	185-264	320-450	185-264	185-264
Frequency (Hz)	45-65						
Power factor	1						
Charge voltage 'absorption' (V DC)	28,5	28,5	28,5	28,5	28,5	57	57
Charge voltage 'float' (V DC)	26,5	26,5	26,5	26,5	26,5	53	53
Charge current house batt. (A) (2)	30 / 50	50	75	100	100	25	50
Charge current starter batt. (A)	4	4	4	4	4	n. a.	n. a.
Charge characteristic	luoUo (three step)						
Battery capacity (Ah)	150-500	250-500	400-800	500-1000	500-1000	125-250	250-500
Temperature sensor	✓						
Can be used as power supply	✓						
Potential free contacts	✓						
Forced cooling	✓						
Protection (1)	a,b,c,d						
Operating temp. range	-20 to 60°C (0 - 140°F)						
Humidity (non condensing)	max 95%						
ENCLOSURE							
Material & Colour	aluminium (blue RAL 5012)						
Battery-connection	M8 studs						
230 V AC-connection	screw-clamp 2,5 mm ² (AWG 6)						
Protection category	IP 21						
Weight kg (lbs)	5,5 (12.1)	13 (28)	10 (22)	10 (22)	23 (48)	5,5 (12.1)	10 (12.1)
Dimensions hxxwxd in mm (hxxwxd in inches)	365x250x147 (14.4x9.9x5.8)	365x250x257 (14.4x9.9x10.1)	365x250x257 (14.4x9.9x10.1)	365x250x257 (14.4x9.9x10.1)	515x260x265 (20x10.2x10.4)	365x250x147 (14.4x9.9x5.8)	365x250x257 (14.4x9.9x10.1)
OPTIONS							
Temperature sensor	✓						
Charger output panel	✓						
Charger switch panel	✓						
Battery alarm panel	✓						
STANDARDS							
Safety	EN 60335-1, EN 60335-2-29						
Emission	EN 55014-1, EN 61000-3-2						
Immunity	EN 55014-2, EN 61000-3-3						

- 1) Protection
 a. Output short circuit
 b. Battery reverse polarity detection
 c. Battery voltage too high
 d. Temperature too high

- 2) Up to 40°C (100°F) ambient

Accessories



BMV 501 Battery Monitor

The BMV – 501 Battery Monitor features an advanced microprocessor control system combined with high resolution measuring systems for battery voltage and charge/discharge current. Besides this, the software includes complex calculation algorithms, like Peukert's formula, to exactly determine the state of charge of the battery. The BMV – 501 selectively displays battery voltage, current, consumed Ah or time to go. The monitor also stores a host of data regarding performance and use of the battery.



Charger Output

Reduces the maximum output current of the charger. This panel can also be useful if the shore power fuse is limited: the AC current drawn by the battery charger can be controlled by limiting the maximum output current, thereby preventing the shore power fuse from blowing.



Charger Switch

A remote on-off switch



Battery Alarm

An excessively high or low battery voltage is indicated by an audible and visual alarm.