

ESP PANELS™ & SYSTEM COMPONENTS

Brochure, instruction and connection manual - issue 2



Panel range

System monitoring panel
ESP-SYSTEM

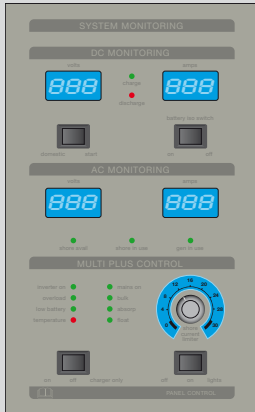

Control panel
ESP-CONTROL

AC circuit breaker panel
ESP-AC-20A-11

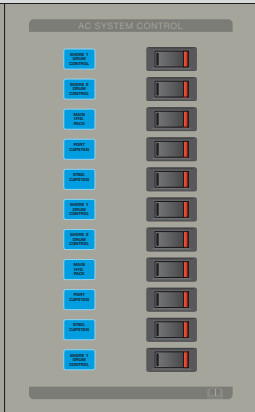

AC circuit breaker panel
ESP-AC-20A-04

DC circuit breaker panel
ESP-DC-20A-11

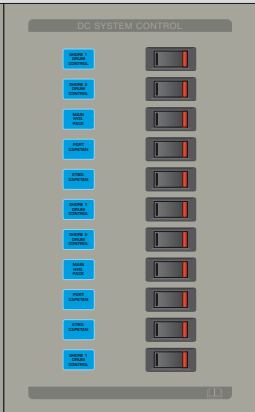

DC circuit breaker panel
ESP-DC-20A-04

Tank control panel
ESP-TANK

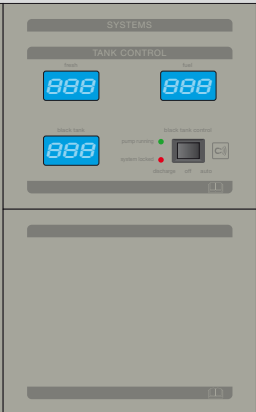

ESP 52mm gauge panel
ESP-52

ESP VE-Net panel quarter
ESP-VE.NET QTR

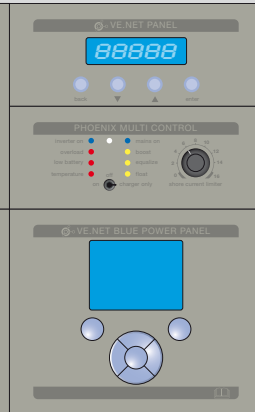

ESP Phoenix Multi Control panel
ESP-MULTI

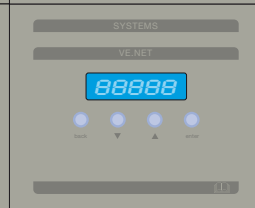

ESP VE-Net Blue Power panel
ESP-VE.NET BLUE

VE.NET panel half
ESP-VE.NET HALF

Connections to ESP DC Breaker Panel

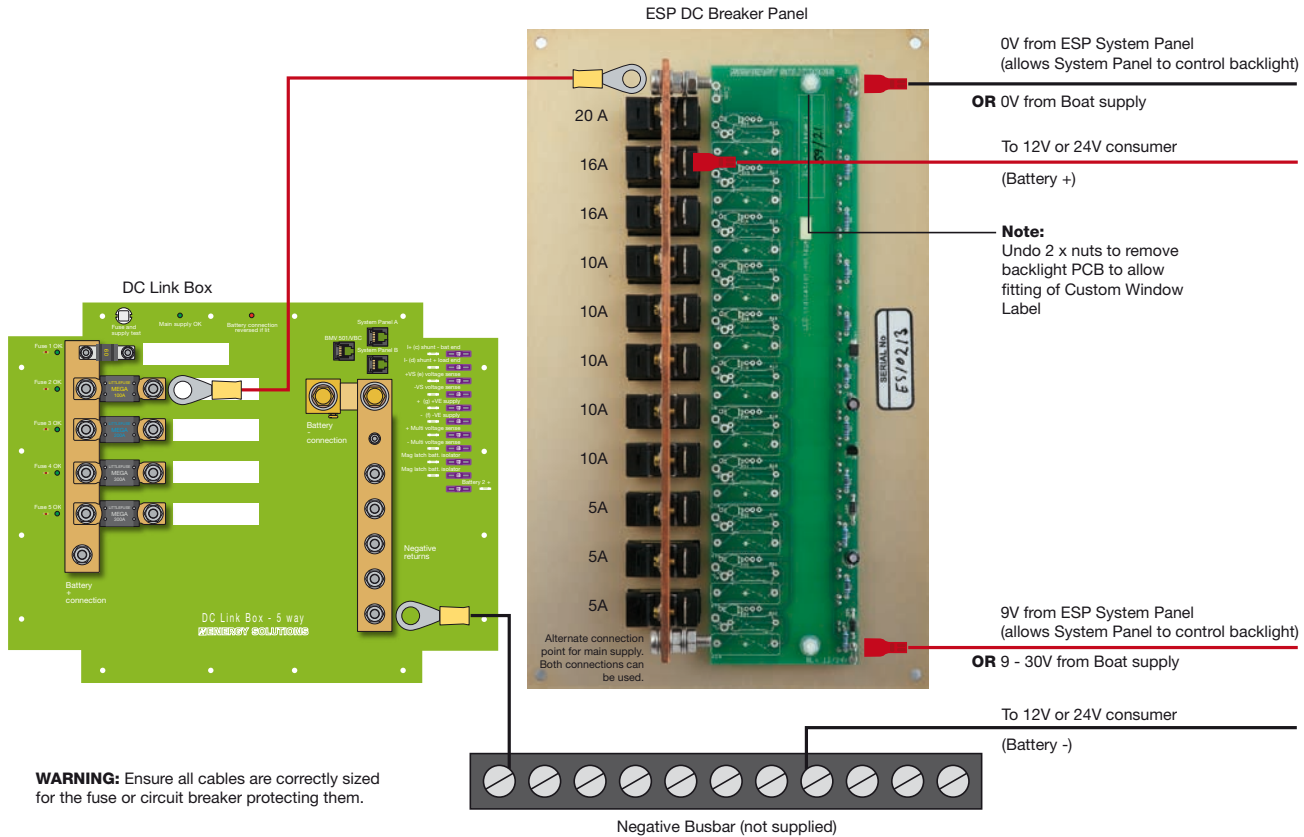

Connections to ESP AC Breaker Panel - with single AC group

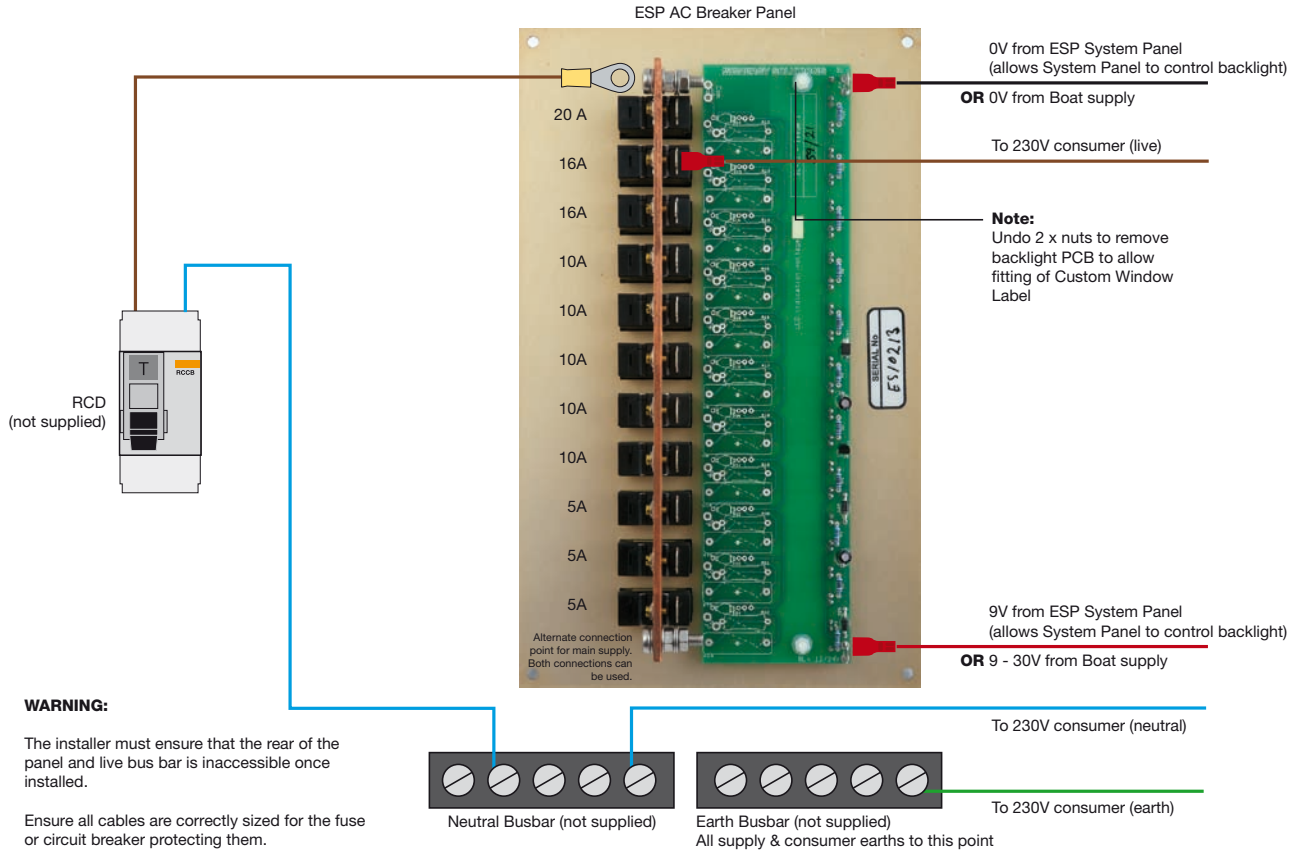

Connections to ESP AC Breaker Panel - with two AC groups

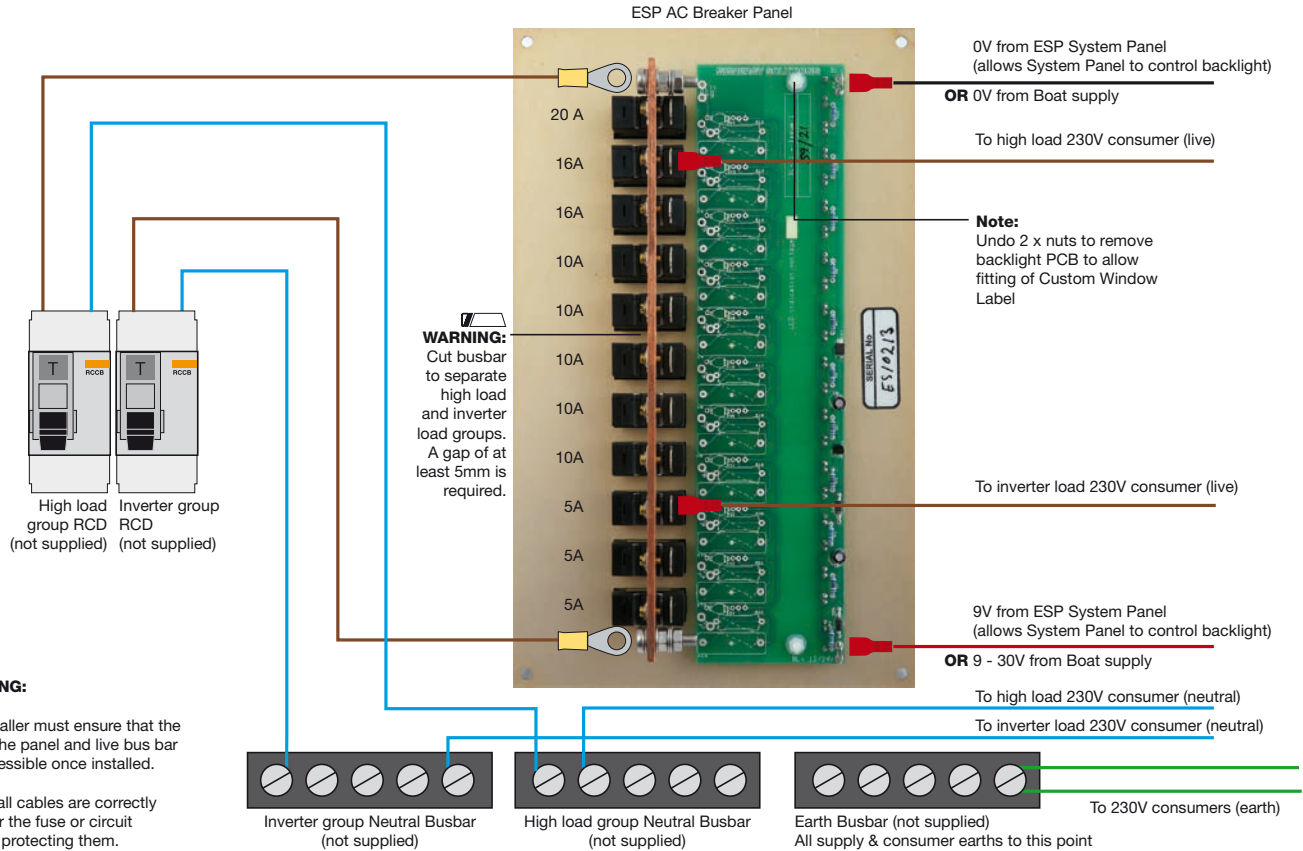

Control Panel

9V from ESP System Panel
(allows System Panel to control backlight)
OR 9 - 30V from Boat supply

0V from ESP System Panel
(allows System Panel to control backlight)
OR 0V from Boat supply

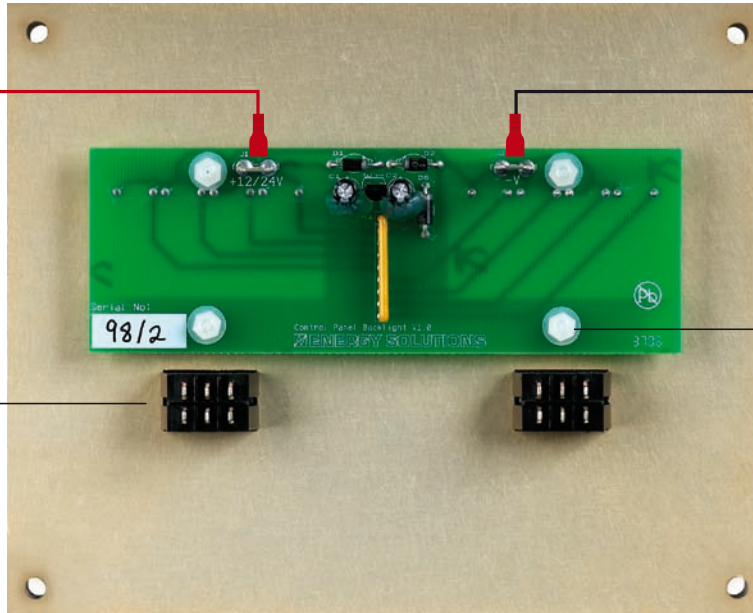

Note:

A connection PCB is supplied loose. This allows alternate switch actions to be fitted prior to the connection PCB being soldered onto the switch. Your distributor can fit the PCB and switch at time of ordering.

Switch capacity is 4 Amps max.

Switch supplied is centre off momentary either way.

Note:

Undo 4 x nuts to remove backlight PCB to allow fitting of Custom Window Label

Alternative switch actions can be purchased separately:

- ON-OFF
- ON-ON
- ON-OFF-ON
- ON-MOMENTARY
- ON-OFF-MOMENTARY
- MOMENTARY-OFF-MOMENTARY

Connections to Tank Control Panel & Pump Relay Box

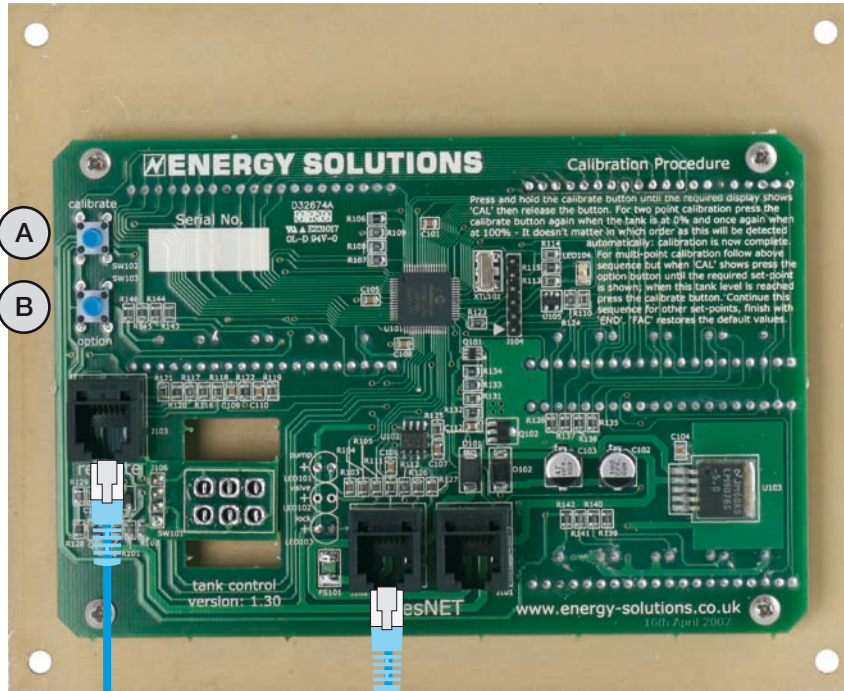

RJ12 to ESP System Panel for backlight control (backlights always on if not used)

Key:

- A. Calibrate button
- B. Option button
- C. Sea Cock aux contact connections
- D. Relay connection terminals
- E. 12/24v battery supply (Via 3Amp fuse or circuit breaker)

The sender connections in relay box are:

- (1) - Black Tank
- (2) - Fresh Water
- (3) - Fuel

Relay Outputs

Six 8 Amp relays are provided for customer use. The relays are magnetically latching so consume no power in a steady state. All relays come with default settings. Relays one to four can be re-programmed on request by the factory for an additional charge.

The relays are set to:

- Relay #1 Black tank discharge pump**
- controlled by panel switch, on @ 75% off @ 5%.
- Relay #2 Black tank toilet lock**
- on @ 95% off @ 90%.
- Relay #3 Fresh water tank pump protection**
- on @ 10% off @ 5%.
- Relay #4 Fresh water tank fill alarm / fill control**
- on @ 95% off @ 90%.
- Relay #5 Fuel tank fuel low alarm / fuel transfer**
- on @ 10% off @ 15%.
- Relay #6 Fuel tank fill alarm / fill control**
- on @ 95% off @ 90%.

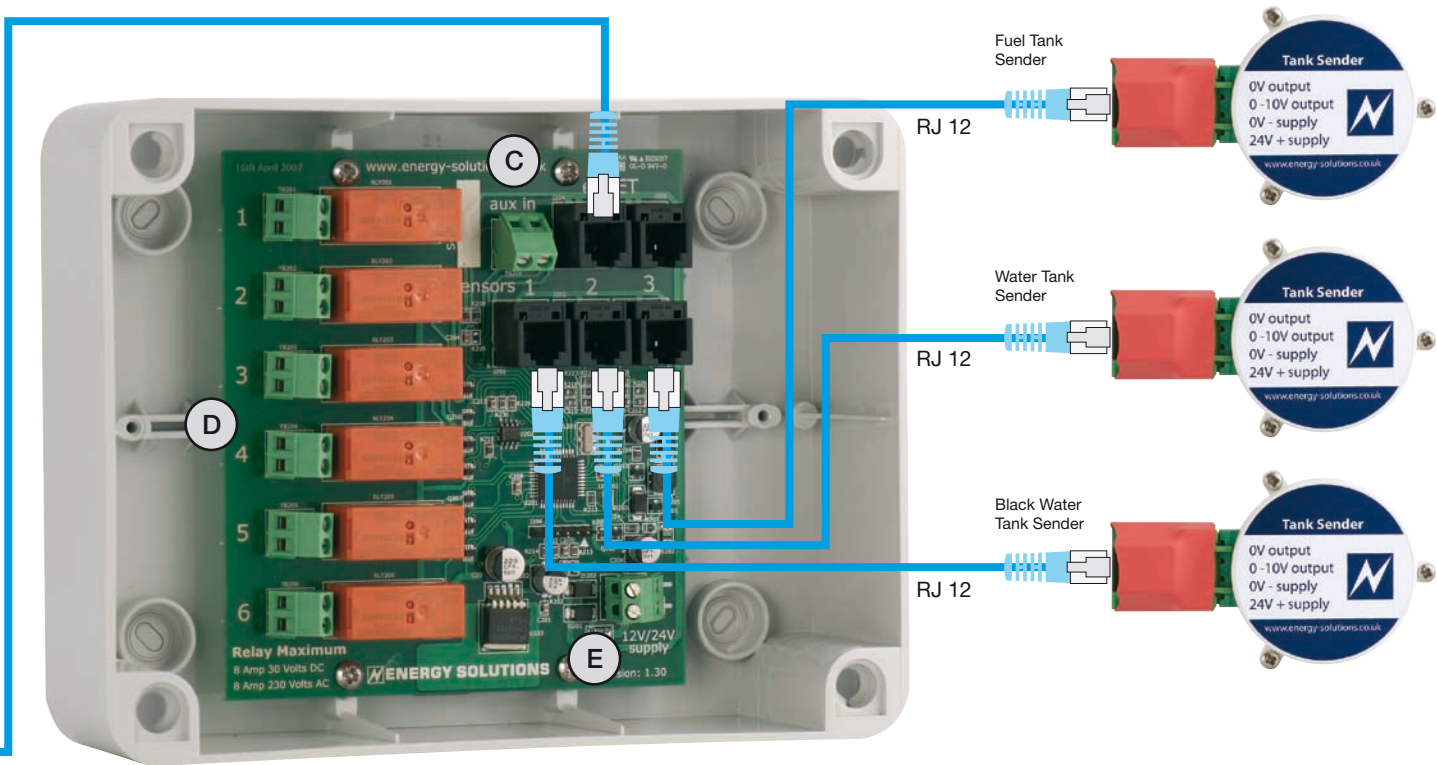

ESP AC Changeover

The system panel acquires its AC voltage and current from the ESP PowerMan Unit. These provide automatic switching between shore power, generator and MultiPlus. In addition, high load circuits are disconnected when only Inverter power is available.

AC Changeover 20A

Designed for systems with up to 5Kw generator and one MultiPlus unit.



AC Changeover 32A

Designed for systems with up to 8Kw generator and one or two MultiPlus units.



AC Changeover 64A

Designed for systems with up to 16Kw generator and two to four MultiPlus units

DC Link Box & ES Intelligent Shunt



The system panel acquires its DC voltage and current from the DC Link Box or ES Intelligent Shunt.

The Link Box provides primary protection for heavy DC consumers and avoids "spaghetti junction" wiring at the battery terminal.



Custom window labels

The Breaker and Control Panels are designed to accept custom legends, to suit your needs.

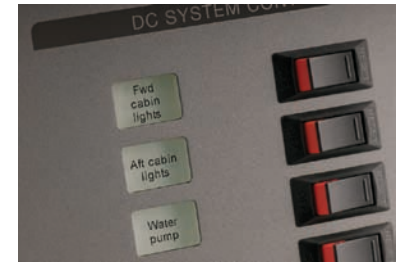

Easy to use MS Word templates for these are available for download at: www.energy-solutions.co.uk/esp

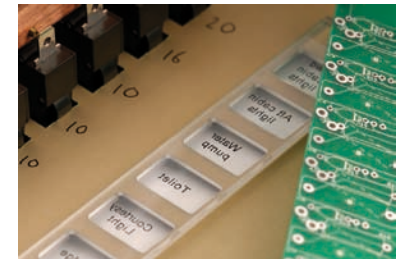

Simply fill these in, print on Laser Film and cut to size. To install the label, remove the backlight PCB by undoing the securing nuts. Lay the label onto the rear of the window and reassemble.

DC Link Box

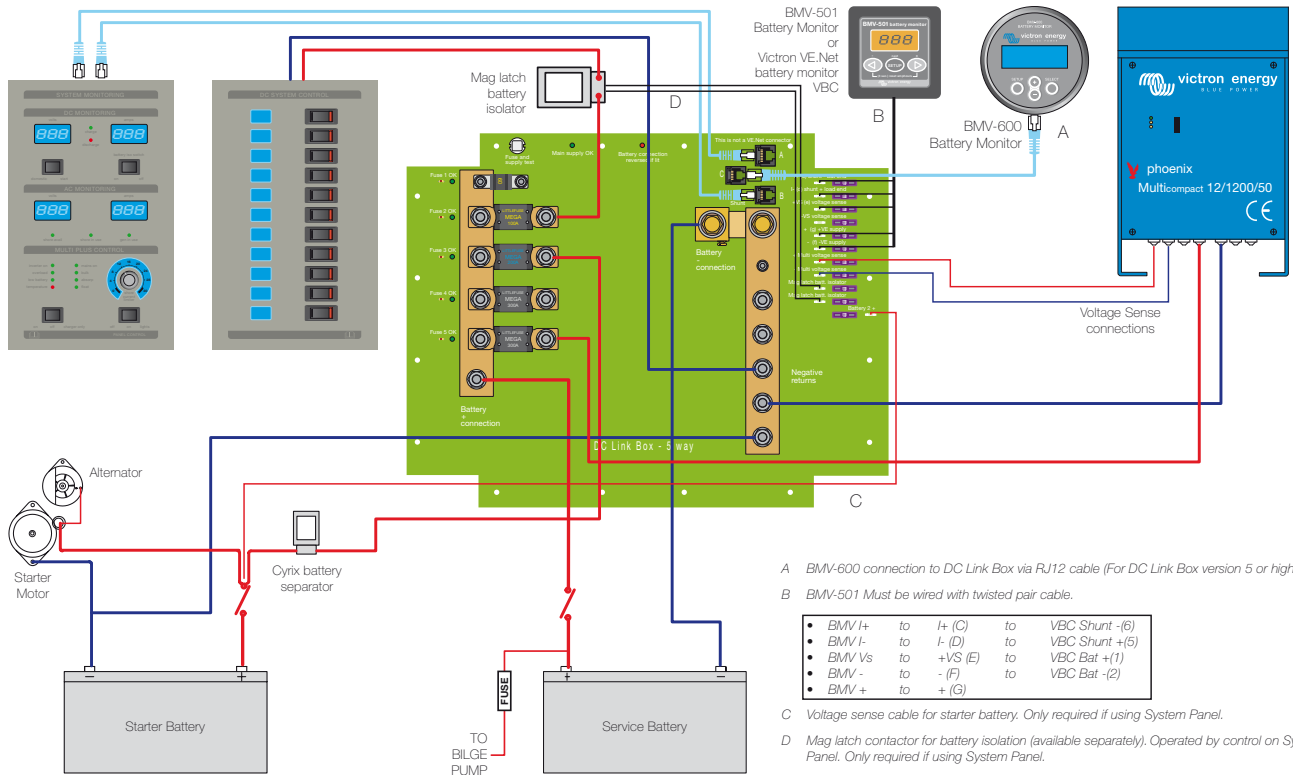

A BMV-600 connection to DC Link Box via RJ12 cable (For DC Link Box version 5 or higher)

B BMV-501 Must be wired with twisted pair cable.

• BMV I+ to I+ (C) to VBC Shunt -(6)
• BMV I- to I- (D) to VBC Shunt +(5)
• BMV Vs to +VS (E) to VBC Bat +(1)
• BMV - to -(F) to VBC Bat -(2)
• BMV + to +(G)

C Voltage sense cable for starter battery. Only required if using System Panel.

D Mag latch contactor for battery isolation (available separately). Operated by control on System Panel. Only required if using System Panel.

System In A Box™ schematic wiring diagrams

SYSTEM IN A BOX™ with MultiPlus

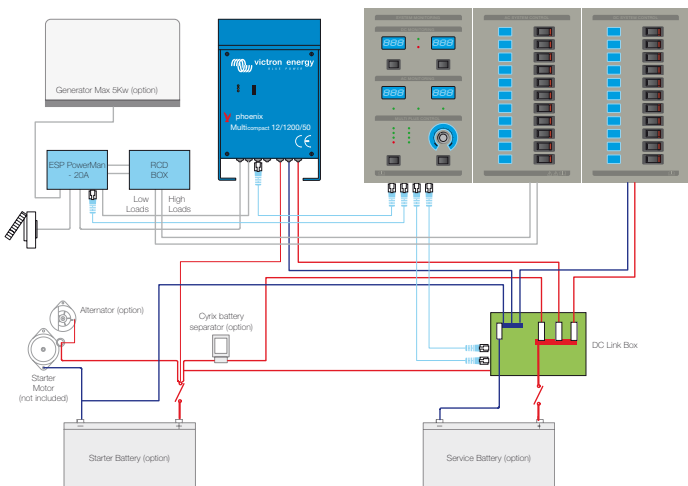

SYSTEM IN A BOX™ with Multi EasyPlus

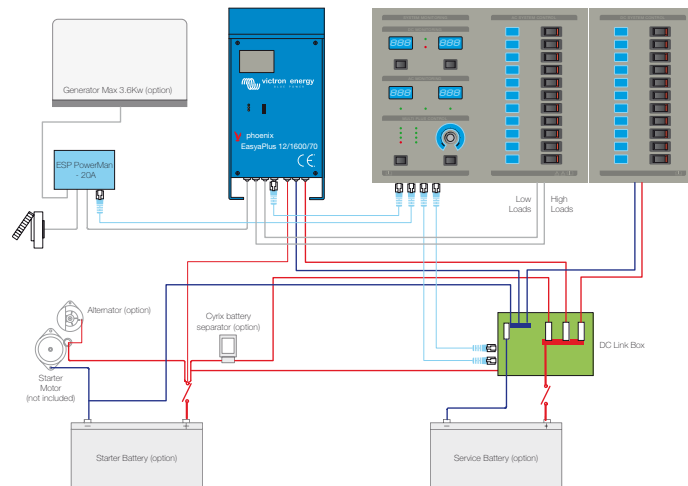

Connection functionality

1. By connecting a battery monitor to the AC Changeover the alarm relay can be used to disconnect high power distribution
2. Connect the Duo Multi Control panel to the AC Changeover to allow the Multi to recognise if you are operating on shorepower or generator for power assist functions
3. By connecting the Multi virtual switch to the AC Changeover the Multi can be used to disconnect high load consumers

AC Changeover 20A connection diagram - MultiPlus

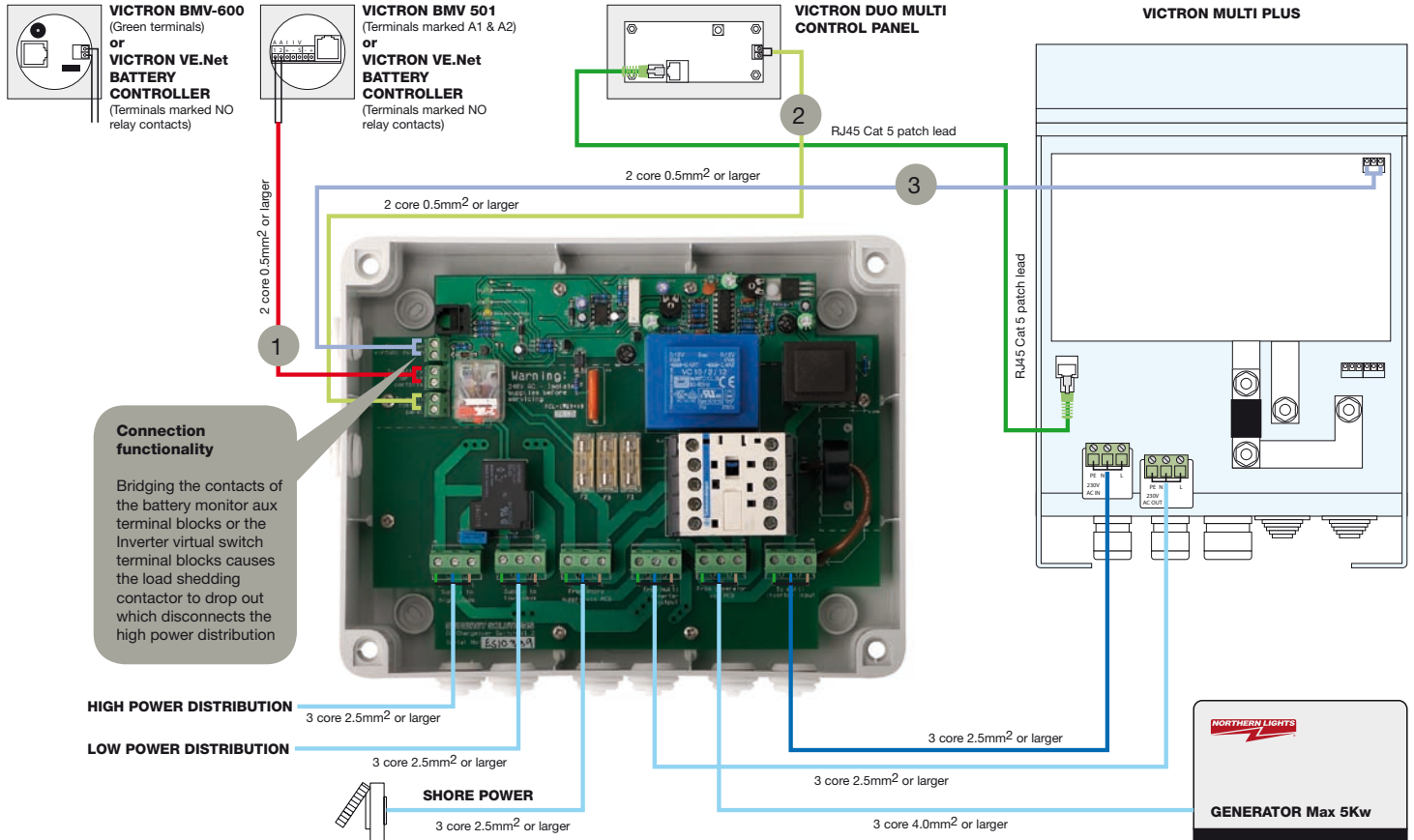

AC Changeover 32A connection diagram

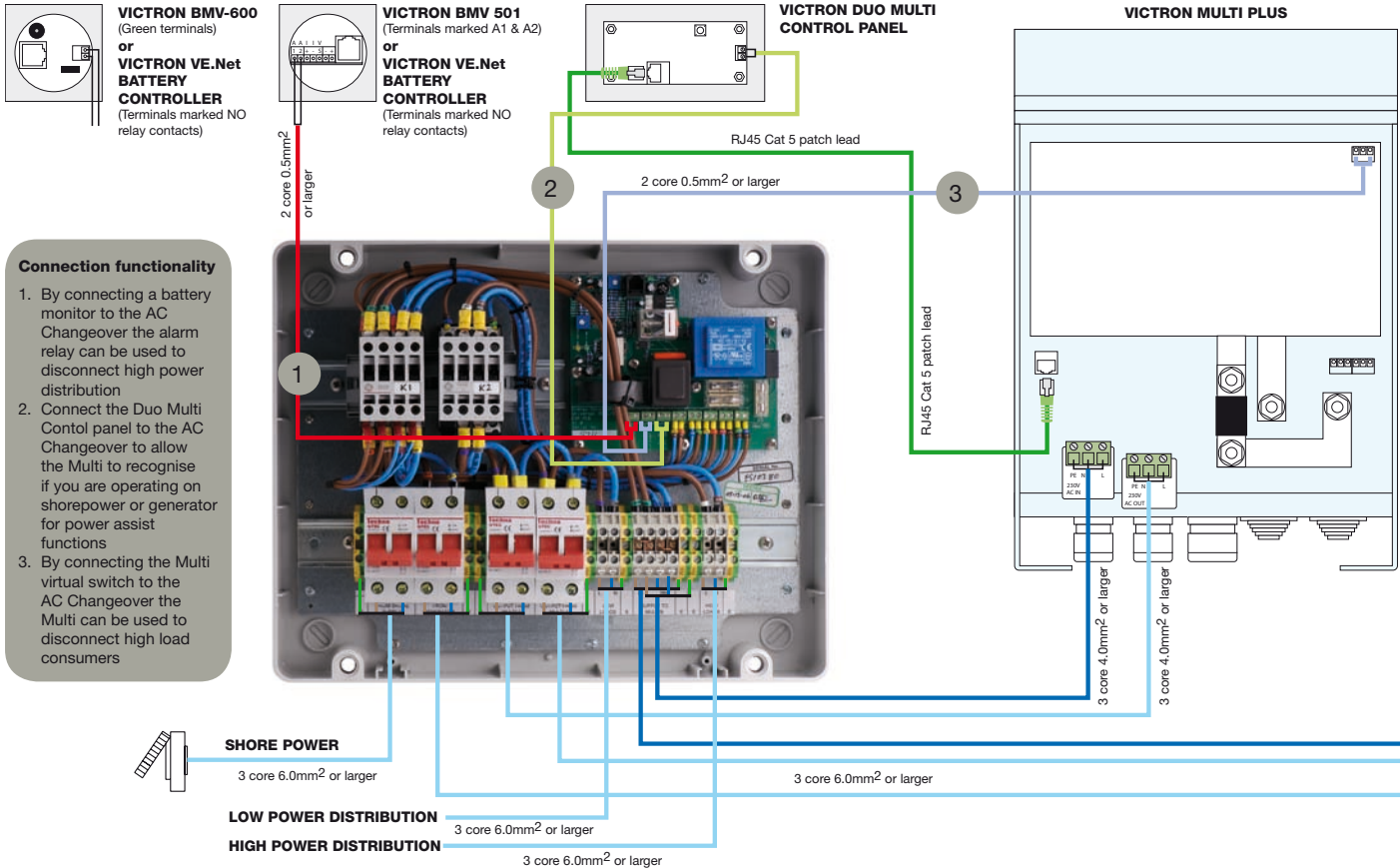

Connection functionality

1. By connecting a battery monitor to the AC Changeover the alarm relay can be used to disconnect high power distribution
2. Connect the Duo Multi Control panel to the AC Changeover to allow the Multi to recognise if you are operating on shorepower or generator for power assist functions
3. By connecting the Multi virtual switch to the AC Changeover the Multi can be used to disconnect high load consumers

OPTIONAL SECOND - VICTRON MULTI PLUS

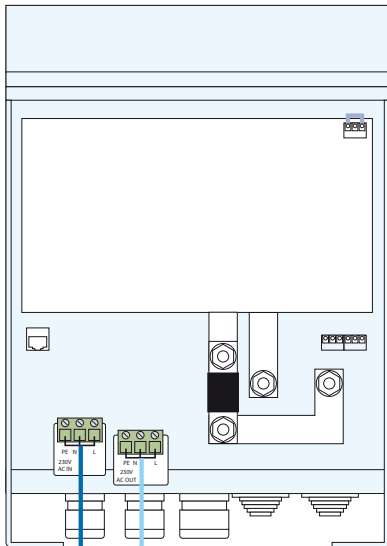

3 core 4.0mm² or larger

3 core 4.0mm² or larger



Termination detail

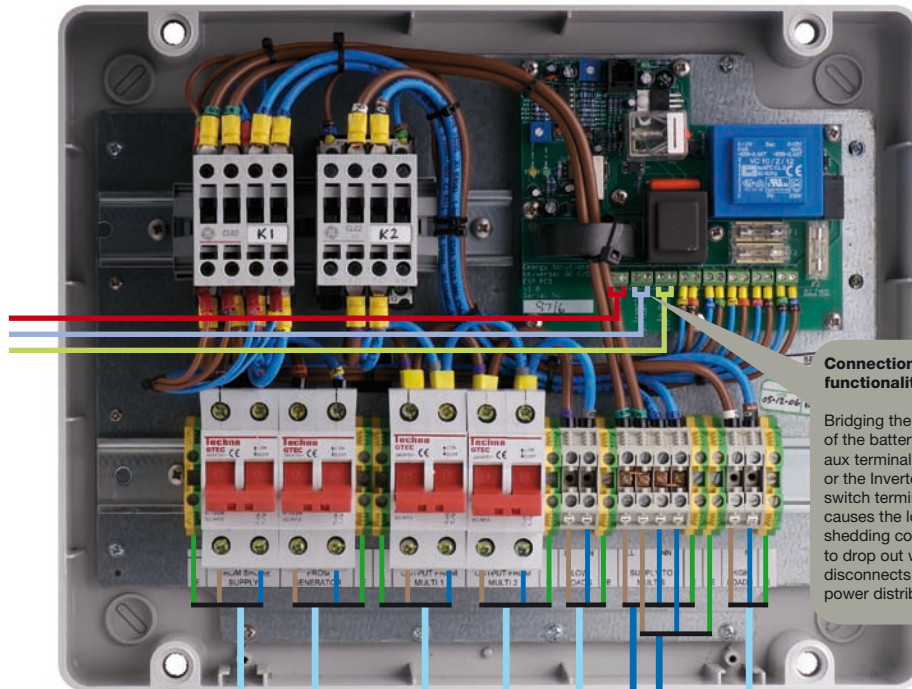

Connection functionality

Bridging the contacts of the battery monitor aux terminal blocks or the Inverter virtual switch terminal blocks causes the load shedding contactor to drop out which disconnects the high power distribution

AC Changeover 20A connection diagram - EasyPLUS

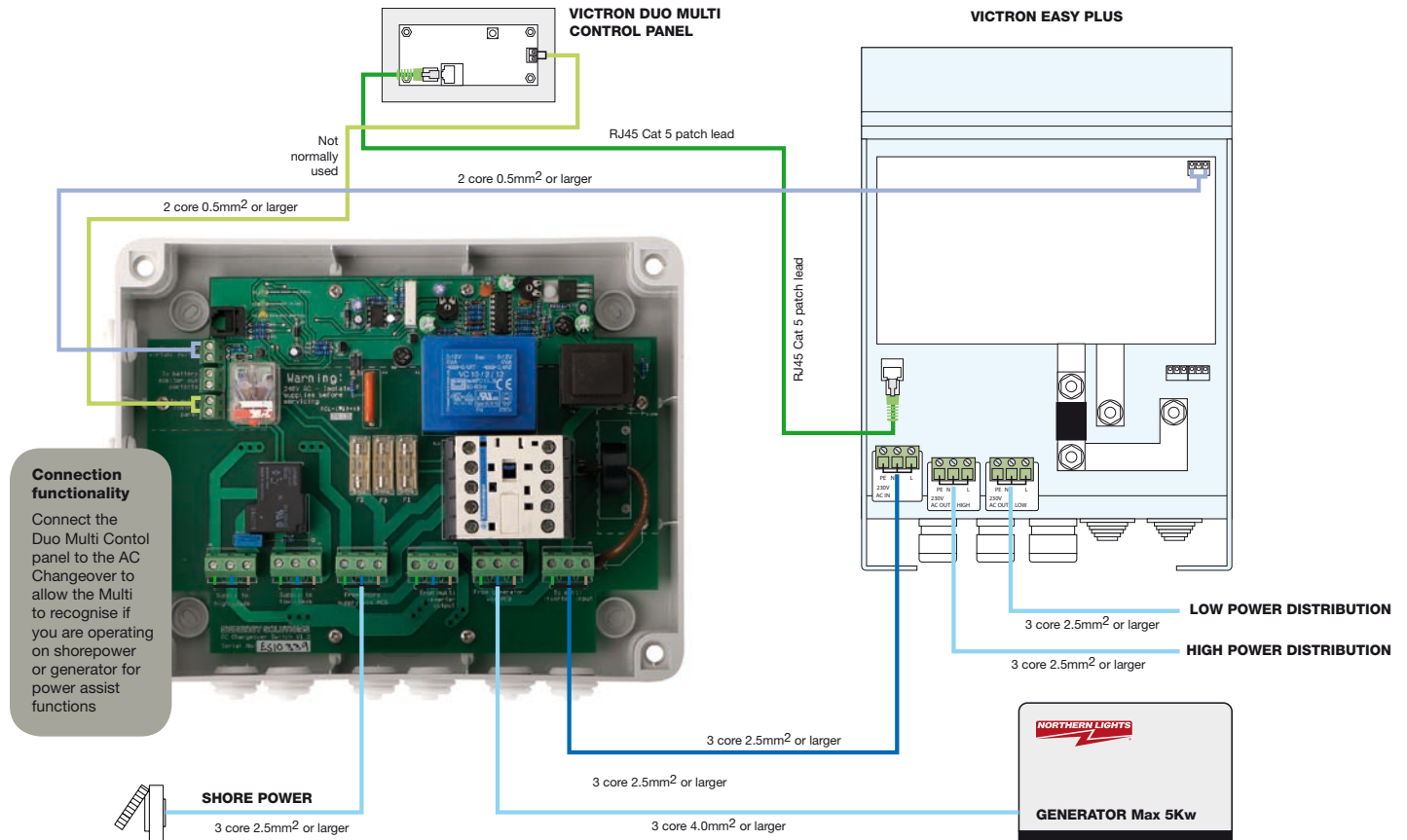

Product Dimensions

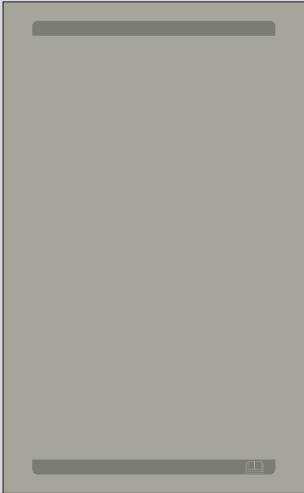

Full size panels:

System monitoring panel
ESP-SYSTEM

AC circuit breaker panel
ESP-AC-20A-11

DC circuit breaker panel
ESP-DC-20A-11

All panels:
160mm(W) x 260mm(H)



Half size panels:

ESP VE-Net Blue Power panel
ESP-VE.NET BLUE

VE.Net Panel
ESP-VE.NET

AC circuit breaker panel
ESP-AC-20A-04

DC circuit breaker panel
ESP-DC-20A-04

Control panel
ESP-CONTROL

Tank control panel
ESP-TANK

Blank panel
ESP-BLANK-HALF SIZE

ESP 52mm gauge panel
ESP-52

All panels:
160mm(W) x 130mm(H)



Quarter size panels:

ESP VE-Net panel
ESP-VE.NET

ESP Phoenix Multi Control panel
ESP-MULTI

Blank panel
ESP-BLANK- QUARTER SIZE

All panels:
160mm(W) x 65mm(H)

AC Changeover:

AC Changeover 20A - 250mm(L) x 200mm(W) x 95mm(H)

AC Changeover 32A - 380mm(L) x 300mm(W) x 120mm(H)

AC Changeover 64A - 460mm(L) x 380mm(W) x 180mm(H)

DC Link Box:

DC Link Box - 380mm(L) x 300mm(W) x 120mm(H)

ESP PANELS™

ENERGY SOLUTIONS George Summers Close, Medway City Estate, Rochester, Kent ME2 4EL UK
tel: +44 (0)1634 290772 Fax: +44 (0)1634 290773 email: mail@energy-solutions.co.uk web: www.energy-solutions.co.uk